

Drum Lid Mixers

OWNERSMANUAL

Warranty

Our products are guaranteed against defective materials and workmanship, we will repair or replace such items as may prove defective at our option. Warranty period is one year on items manufactured by INDCO, except for the MixMaster Series Shakers which carries a two year warranty. On items not manufactured by INDCO, the manufactures warranty applies. All component parts of our products are covered by this warranty, except for normal wear items such as belts or impellers. We cannot be responsible for damage or abuse to equipment caused by improper installation or operation. Warranties can also be voided by unauthorized disassembly of equipment. For warranty repairs, equipment is returned to INDCO at the customer's expense; we will repair and return to customer at our expense. Under no circumstances will we allow labor charges or other expense to repair defective merchandise. This warranty is exclusive and is in lieu of all other warranties, whether express or implied. INDCO shall not be liable for any other damages, whether consequential, indirect, or incidental, arising from the sale or use of its products.

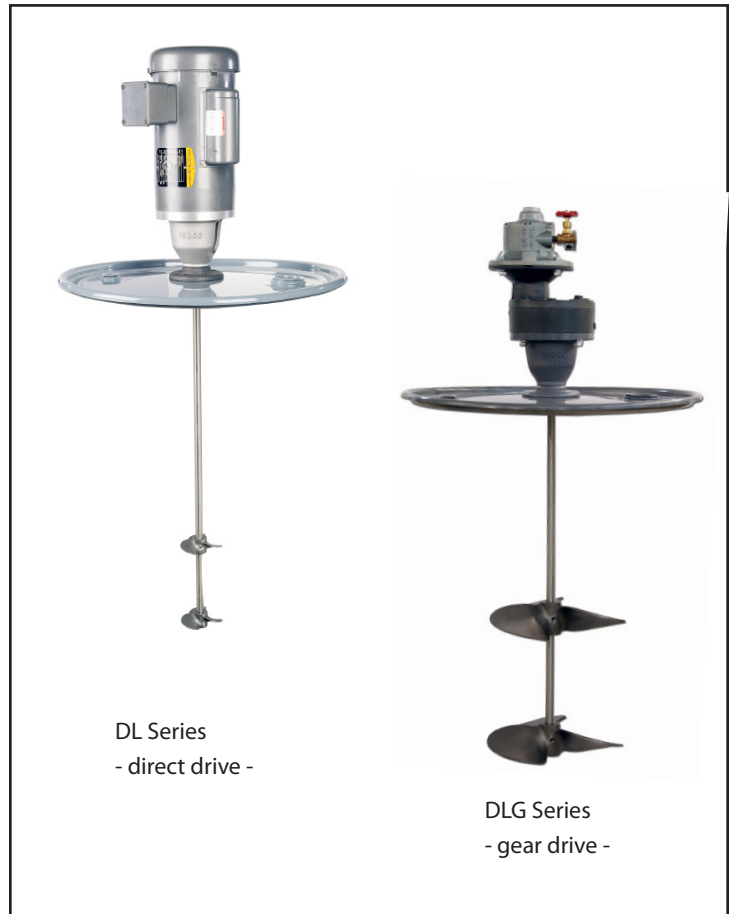

DL(G) Drum Lid Series Mixers

TABLE OF CONTENTS:

Safety & General	2
Receiving & Installation.....	3
Operation	4
Parts List.....	5-10

P4040 Earnings Way • NEW ALBANY, IN 47150 •
P: 812-941-5954 F: 812-944-9742 •
INDCO.COM • INFO@INDCO.COM

Safety:

Please follow the below safety precautions. If there are any questions, please call INDCO at 800-942-4383. Please read this complete manual before trying to operate your mixer. Failure to follow these instructions could result in serious bodily injury or death.

- Do not touch moving parts while mixer is operating. Do not wear loose-fitting clothes or jewelry around an operating mixer. Keep all hands, feet, clothes, neckties, necklaces and other objects clear of moving parts.
- Never move the unit without a suitable lifting device.
- Have a qualified individual bring power to your unit.
- Always ground the unit. Never use an extension cord.
- Never run the unit in open air.
- Never adjust the speed without the unit running.
- Always lockout the power when working on the unit.

ELECTRIC MOTOR SAFETY:

Motors should be installed, protected and fused in accordance with latest issue of National Electrical Code, NEMA Standard Publication No. MG 2 and local codes. Frames and accessories of motors should be grounded in accordance with National Electrical Code (NEC) Article 430. For general information on grounding refer to NEC Article 250. Not all rotating parts are guarded. Keep hands and clothing away from moving parts. Trained, qualified personnel should make electrical repairs and non-standard connections. If environment has hazardous combustible fumes present, use only explosion-proof electric motors.

AIR MOTOR SAFETY:

The air motor is designed to be driven by compressed air and under no circumstances be driven with any other gases. Fluids, particles, solids or any substance mixed with air, particularly combustible substances likely to cause explosions, must not drive air motor.

- Do not drive with flammable or explosive gases or operate unit in an atmosphere containing them.
- Air motor is designed for air only. Do not allow corrosive gases or particulate material to enter motor. Water vapor, oil-based contaminants, or other liquids must be filtered out.
- Do not use a hammer or force coupling or drive pulley onto shaft when installing drive onto air motor. This causes end thrust that could damage air motor.
- Ambient temperature should not exceed 250°F.
- Beware of any exposed and/or movable parts. Proper guards should be in place to prevent personal and/or property damage.
- Solid or liquid material exiting unit can cause eye or skin damage. Keep away from air stream.
- Always disconnect air supply before servicing.
- Do not allow air motor to "run free" at high speeds with no loads. Excessive internal heat build-up, loss of internal clearances and rapid motor damage will result.
- Some models may exceed 85dB(A) sound level. Hearing protection should be worn when in close proximity to these models.

General:

- Single-phase TEFC models include cord, plug and switch.
- EP models must be wired in the field by the user.
- DC-Variable-Speed electric models have a controller mounted to the mixer and they are pre-wired.
- Air motors include exhaust muffler.

DL - DIRECT DRIVE SERIES

This line of drum lid mixers offer a low cost method of agitating and blending 55-gallon open head drums of low viscosity liquids. All units include steel drum lids.

DLG - GEAR DRIVE SERIES

This line of rugged, heavy duty drum lid mixers are ideal for vigorous mixing of heavy-bodied coatings, epoxies, mud, plaster and slurries. Built around a 5:1 ratio gear box, they have extra power and high torque necessary for tough drum and tank mixing jobs. All units include steel drum lids.

Receiving:

Before removing any packing, visually inspect the exterior of the shipment for any sign of damage. Should there be any damage, bring it to the attention of the delivering UPS or truck line and note the same on the receiving ticket. Should there be damage you must place a claim with the truck line. They are the only ones who will pay for the damage done and you are the only one who can place that claim.

Installation:

Your new mixer is supplied, assembled, and complete except for the impeller(s) and impeller-shaft which have to be fitted to the machine before it's operational.

Shaft & Coupler

To install mixer shaft, back off the set screws as far as possible without removing them. Insert mixing shaft into the coupler as far as it will go. Tighten the set screws firmly to secure the shaft to the coupler.

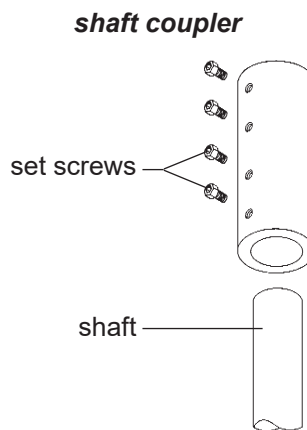

Gear Drive, DLG Series

- The gear box is filled with oil.
- The brass plug supplied loose is a Filler-Vent Plug. After mounting the mixer, install the Filler-Vent Plug in the highest filler point as shown below.

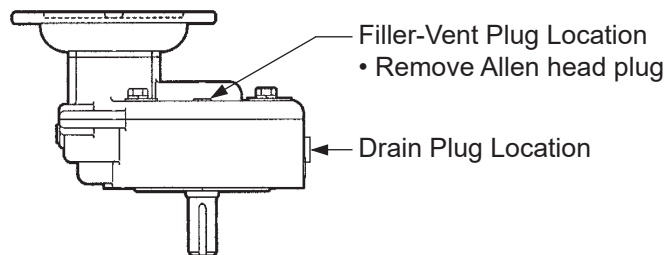

IMPELLERS:

To install the impeller, back off the set screw(s) as far as possible without removing them. Insert mixing shaft into the bore and tighten the set screw(s) firmly to secure the shaft to the impeller.

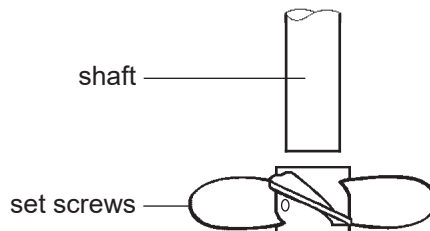

IMPELLER PLACEMENT:

For mixers with ONE impeller, mount it 1 to 2 impeller diameters off the bottom of the mixing container. For mixers with TWO or more impellers, mount the lowest impeller 1 to 2 diameters distance off the bottom of mixing container. Mount the imellers 1 to 2 impeller diameters apart. The uppermost impeller should be positioned approximately 1 impeller diameter under the surface of the liquid. The above guidelines are “rules of thumb” and may not be the best for your situation. Experimenting with impeller placement may provide your best results.

Operation:

ELECTRIC POWER: Once the electric motor has been wired. check rotation to be sure the mixer shaft is rotating in a clock-wise direction, looking downward into the container.

AIR POWER: Check to ensure the air valve in in the closed position, then connect air supply. Check rotation to be sure the mixer shaft is rotating in a clock-wise direction, looking downward into the container.

Once the mixer is in the container, it is now safe to operate.

Caution:

- Never run the mixer without a propeller.
- Never run the propeller in open air.
- Never run propeller outside a container.

MAINTENANCE:

Maintaining your mixer is not difficult if you follow these guidelines:

- Keep the mixer clean.
- Check all set-screws and fasteners, tighten as needed.
- Check all wiring on a regular basis and repair as needed.
- Air motor powered units:
 - Keep air supply dry and oil in the lubricator.

LUBRICATION:

Gear Drive Models:

The gearbox contains oil from the factory. The recommended replacement oil is:

Gearbox models #RPQ1 and #RPQ2:

- Mobil Extra Hecla
- Shell Oil Omala 680
- Texaco Meropa 680
- or equivalent to above
 - For 50°F to 125°F ambient.
 - RPQ1 Oil capacity is 11 ounces.

PARTS LIST - DRIVE MOTORS

Item 100 Part No. Description

Air Motors

3/4 HP

MTR-3/4-HUB-AIR-CCW	Hub Mount - 3/4 HP	(2AM-NCC-16)	CCW rotation only
N-K202	Repair Kit*	(2AM-NCC-16)	
MTR-3/4-FOOT-AIR-CCW	Foot Mount - 3/4 HP	(2AM-FCC-1)	CCW rotation only
N-K202	Repair Kit*	(2AM-FCC-1)	
MTR-3/4-56C-AIR	56C Mount - 3/4 HP	(2AM-NRV-90)	bi-rotational
N-K510	Repair Kit*	(2AM-NRV-90)	
HDW-1/4-VALVE	Needle valve, brass - 1/4"		
HDW-2502-SNB	Pipe nipple, steel - 1/4" X 2"		
N-AC980	Muffler, metal		

1.5 HP

MTR-1.5-HUB-AIR	Hub Mount - 1.5 HP	(4AM-NRV-22B)	bi-rotational
N-K205	Repair Kit*	(4AM-NRV-22B)	
MTR-1.5-FOOT-AIR	Foot Mount - 1.5 HP	(4AM-FRV-13C)	bi-rotational
N-K205	Repair Kit*	(4AM-FRV-13C)	
MTR-1.5-56C-AIR	56C Mount - 1.5 HP	(4AM-NRV-50C)	bi-rotational
N-K206A	Repair Kit*	(4AM-NRV-50C)	
HDW-1/4-VALVE	Needle valve, brass - 1/4"		
HDW-25-CNG	Pipe nipple, steel - 1/4" X 7/8"		
N-AC980	Muffler, metal		

4 HP

MTR-4-FOOT-AIR	Foot Mount - 4 HP	(6AM-FRV-5A)	bi-rotational
N-K208	Repair Kit*	(6AM-FRV-5A)	
MTR-4-56C-AIR	56C Mount - 4 HP	(6AM-NRV-11A)	bi-rotational
N-K208	Repair Kit*	(6AM-NRV-11A)	
HDW-1/2-VALVE	Needle valve, brass - 1/2"		
HDW-50-CNG	Pipe nipple, steel - 1/2" X 1-1/8"		
N-AC990	Muffler, metal		

* Repair Kits include: Vanes, shaft seal, o-rings, DE & NDE bearings, body & end cap gaskets.

PARTS LIST - DRIVE MOTORS

Item 100	Part No.	Description			
1/2 HP	MTR-1/2-56C-1-EP	56C, fixed speed	1/2 HP Explosion-Proof	115/230VAC	1-phase
	MTR-1/2-56F-1-EP	56F, fixed speed	1/2 HP Explosion-Proof	115/230VAC	1-phase
	MTR-1/2-56C-1-TEFC	56C, fixed speed	1/2 HP TEFC	115/230VAC	1-phase
	MTR-1/2-56F-1-TEFC	56F, fixed speed	1/2 HP TEFC	115/230VAC	1-phase
	CPG-INLINE-18/3	Cord 18/3 - 6', plug and in-line ON-OFF switch			
	MTR-098000	56C, variable speed	1/2 HP TEFC	115VAC to 90VDC	1-phase
	MTR-DC-CONTROL	DC motor controller, variable speed - 1/3 thru 2HP			
	CPG-18/3	Cord 18/3 - 6' with plug			
	MET-VSO-BRACKET	Angle brackets, mounts v.s. controller to motor (2 req'd)			
	<hr/>				
3/4 HP	MTR-3/4-56C-1-EP	56C, fixed speed	3/4 HP Explosion-Proof	115/230VAC	1-phase
	MTR-3/4-56F-1-EP	56F, fixed speed	3/4 HP Explosion-Proof	115/230VAC	1-phase
	MTR-3/4-56C-1-TEFC	56C, fixed speed	3/4 HP TEFC	115/230VAC	1-phase
	MTR-3/4-56F-1-TEFC	56F, fixed speed	3/4 HP TEFC	115/230VAC	1-phase
	CPG-14/3	Cord 14/3 - 5' with plug			
	SWT-TOGGLE	ON - OFF switch			
	SWT-GUARD	Switch guard			
	MTR-108018	56C, variable speed	3/4 HP TEFC	115VAC to 90VDC	1-phase
	MTR-DC-CONTROL	DC motor controller, variable speed - 1/3 thru 2HP			
	CPG-14/3	Cord 14/3 - 5' with plug			
MET-VSO-BRACKET	Angle brackets, mounts v.s. controller to motor (2 req'd)				
<hr/>					
1 HP	MTR-1-56C-1-EP	56C, fixed speed	1 HP Explosion-Proof	115/230VAC	1-phase
	MTR-1-56F-1-EP	56F, fixed speed	1 HP Explosion-Proof	115/230VAC	1-phase
	MTR-1-56C-1-TEFC	56C, fixed speed	1 HP TEFC	115/230VAC	1-phase
	MTR-1-56F-1-TEFC	56F, fixed speed	1 HP TEFC	115/230VAC	1-phase
	CPG-14/3	Cord 14/3 - 5' with plug			
	SWT-DP-TOGGLE	ON - OFF switch			
	SWT-GUARD	Switch guard			
	MTR-108022	56C, variable speed	1 HP TEFC	115VAC to 90VDC	1-phase
	MTR-DC-CONTROL	DC motor controller, variable speed - 1/3 thru 2HP			
	CPG-14/3	Cord 14/3 - 5' with plug			
MET-VSO-BRACKET	Angle brackets, mounts v.s. controller to motor (2 req'd)				

Electric Motors

PARTS LIST - DL DIRECT DRIVE SERIES

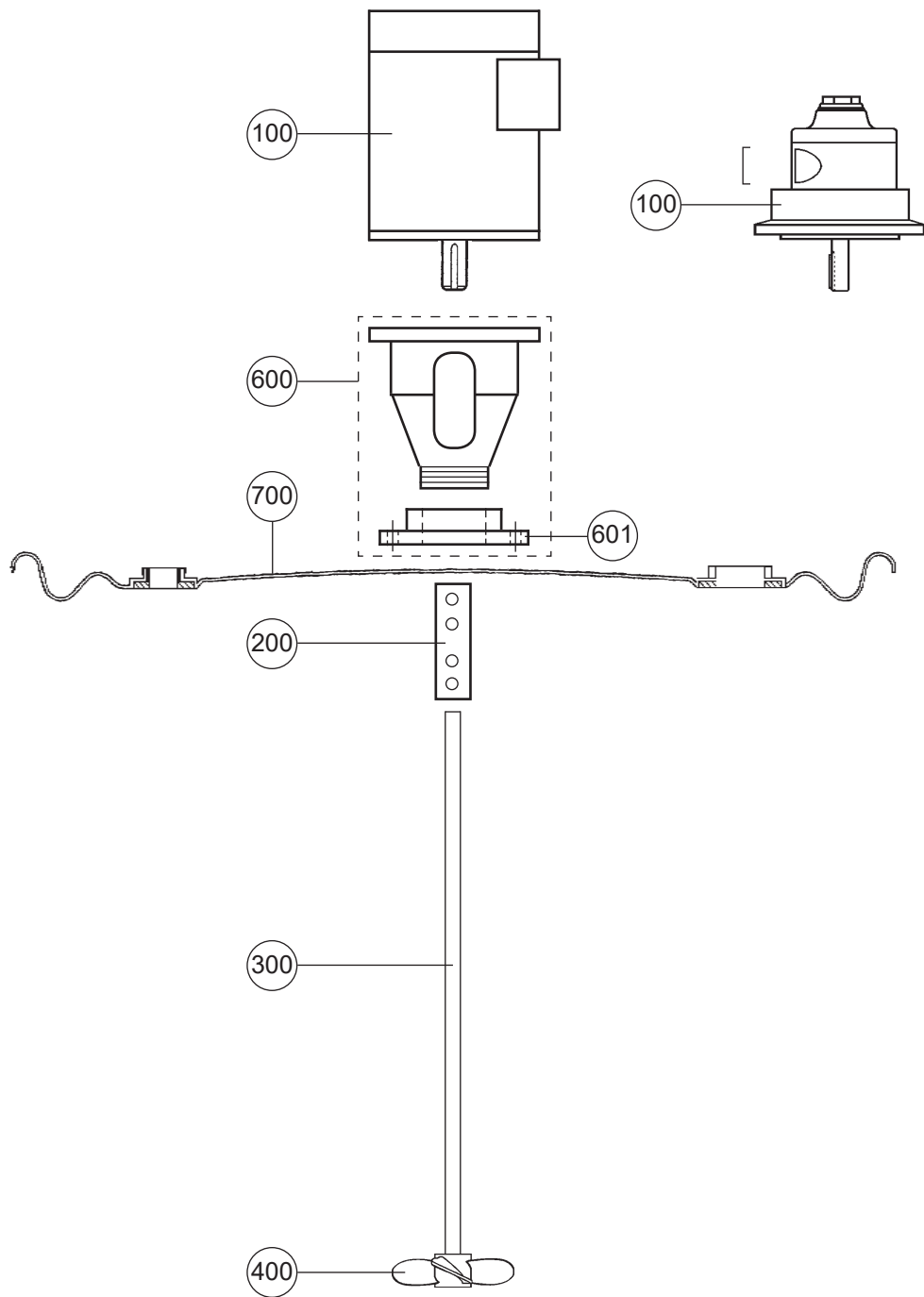

PARTS LIST - DL DIRECT DRIVE SERIES

Item	Qty.	Part No.	Description
100.	1	see 'Parts List - Drive Motors'	Motor, air
100.	1	see 'Parts List - Drive Motors'	Motor, electric
200.	1	CPL-6262	Coupling - shaft, 5/8" bore x 5/8" bore - stainless
300.	1	SS632	Shaft - impeller, 5/8" dia. x 32" long - stainless
400.	1~2	specify model	Impellers
401.	2~4	specify model	Set screw (not shown)

Mounting Base Assembly:

600.	1	N-MNT-FLE	56C Face Mount, Air & Electric motors - cast aluminum w/ floor flange
601.	1	HDW-150-FLANGE	Floor Flange, 1-1/2", 150# - cast iron
700.	1	HDW-BUDL	Drum Lid, 55-gallon - painted steel
700.	1	HDW-BUDL-SS	Drum Lid, 55-gallon - 304 stainless steel

PARTS LIST - DLG GEAR DRIVE SERIES

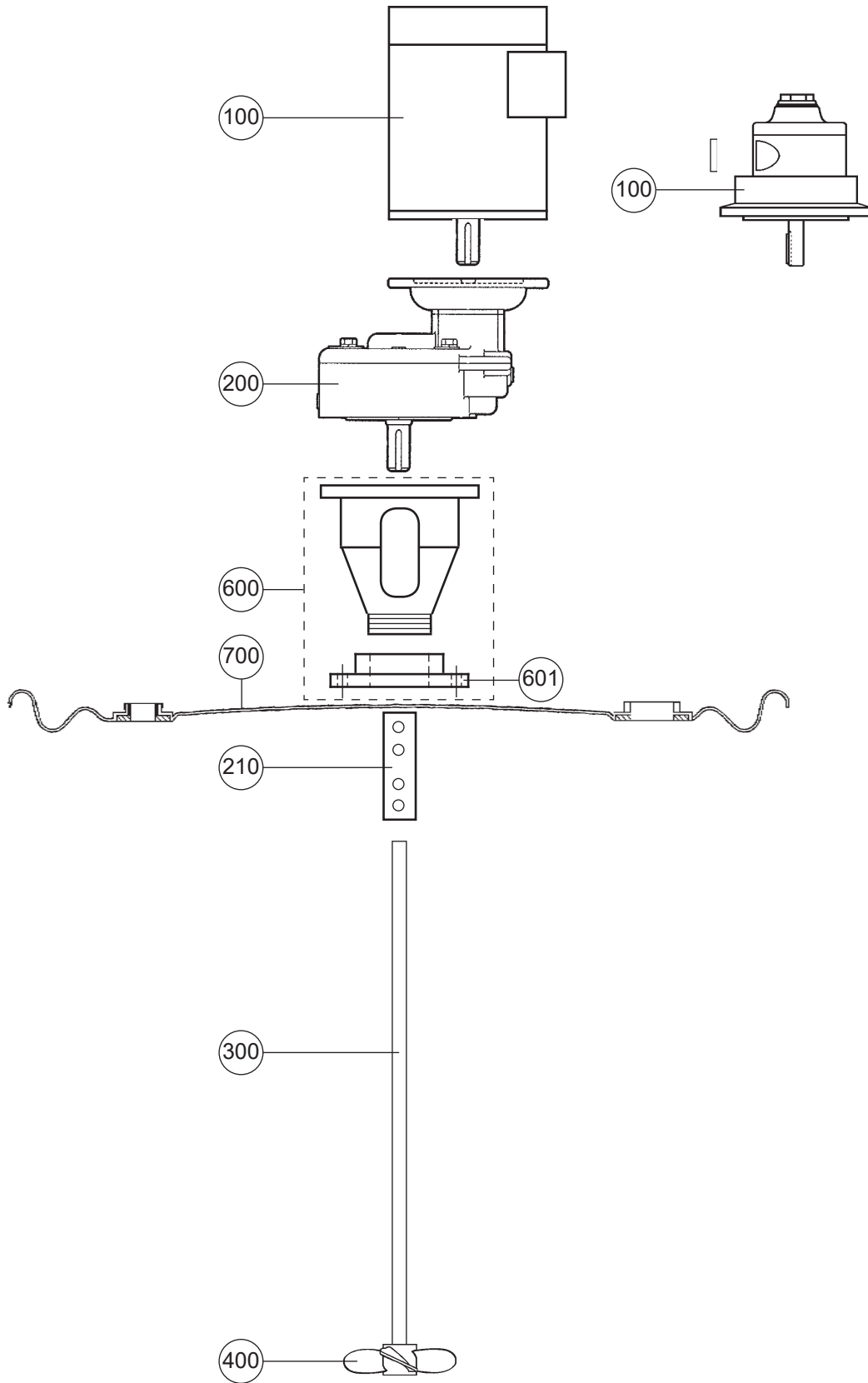

PARTS LIST - DLG GEAR DRIVE SERIES

Item	Description	Part No.	Qty.
100.	Motor, air	see 'Parts List - Drive Motors'	1
100.	Motor, electric	see 'Parts List - Drive Motors'	1
200.	Gear Box, 5:1 ratio	HDW-GB-56C	1
200.	Gear Box, 5:1 ratio for: DLG-4A only	HDW-GB-56C-LG	1
210.	Coupling - shaft, 5/8" bore x 3/4" bore - stainless	CPL-6275	1
300.	Shaft - impeller, 3/4" dia. x 32" long - stainless	SS732	1
400.	Impellers	specify model	1~2
401.	Set screw (not shown)	specify model	
2~4			

Mounting Base Assembly:

600.	56C Face Mount, Air & Electric motors - cast aluminum w/ floor flange	N-MNT-FLE	1
601.	Floor Flange, 1-1/2", 150# - cast iron	HDW-150-FLANGE	1
700.	Drum Lid, 55-gallon - painted steel	HDW-BUDL	1
700.	Drum Lid, 55-gallon - 304 stainless steel	HDW-BUDL-SS	1